

Capacities shown on the tables below refer to housings made of grey cast iron. For housings made of nodular cast iron and cast steel increase displayed values by 80%.

### Capacities of SD-31 housings (Coupling bolts class 8.8)

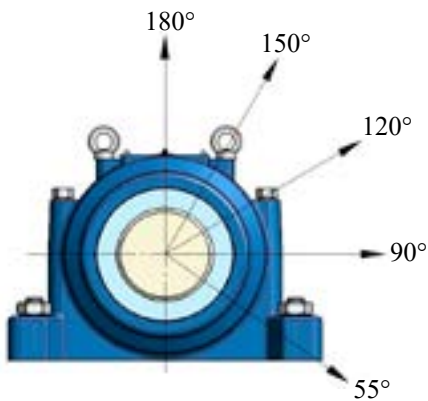

Housing size	Breaking load kN					Flow limit of bolts		
	55°	90°	120°	150°	180°	120°	150°	180°
3134	2100	1000	760	680	850	1500	830	750
3136	2400	1150	850	760	950	1500	830	750
3138	2700	1300	1000	880	1100	2000	1100	1000
3140	3200	1600	1150	1050	1300	2000	1100	1000
3144	4000	1900	1400	1300	1600	2000	1100	1000
3148	4200	2000	1500	1400	1700	3200	1800	1600
3152	4700	2300	1700	1500	1900	3200	1800	1600
3156	5000	2400	1800	1600	2000	3200	1800	1600
3160	6000	2900	2200	1900	2400	3200	1800	1600
3164	7000	3400	2500	2200	2800	3200	1800	1600
3168	7500	3650	2650	2400	3000	3200	1800	1600

### Capacities of SN-30 housings (Coupling bolts class 8.8)

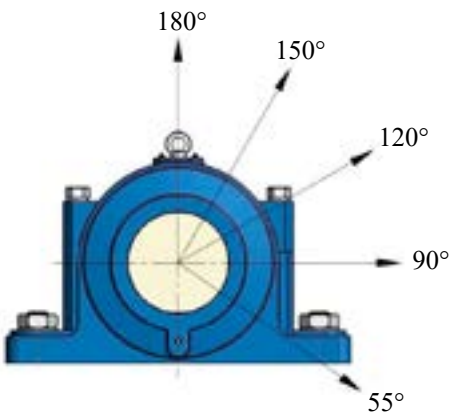

Housing size	Breaking load kN					Flow limit of bolts		
	55°	90°	120°	150°	180°	120°	150°	180°
3024	520	310	230	210	260	260	150	130
3026	620	370	280	250	310	260	150	130
3028	700	420	310	280	350	260	150	130
3030	780	470	350	310	390	260	150	130
3032	840	500	380	340	420	260	150	130
3034	1000	600	450	400	500	380	220	190
3036	1160	700	520	460	580	380	220	190
3038	1300	780	580	520	650	380	220	190
3040	1480	890	670	590	740	380	220	190
3044	1700	1020	760	680	850	630	360	310
3048	1880	1130	850	750	940	630	360	310
3052	2120	1270	950	850	1060	800	460	400
3056	2240	1340	1000	900	1120	800	460	400