

Dimensionales Tamaños 22 la 79

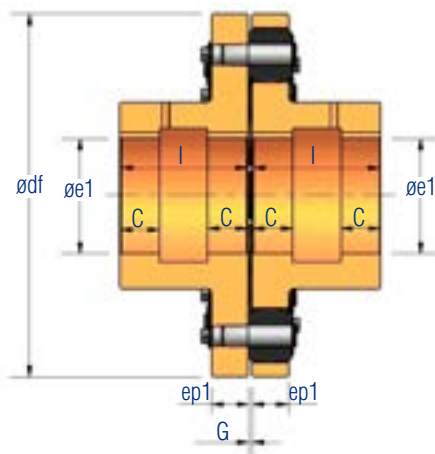

Tamaño	Torque Nominal T <sub>na</sub> (Nm)	Rotación Admisible [rpm]	Diámetros de las Extremidades del Eje (mm)		Dimensiones Generales (mm)					Peso (kg)	Momento de Inercia de los Cubos GD <sup>2</sup> (kgm <sup>2</sup> )
			de	hasta	df	i	ep <sub>1</sub>	C	G	1	1
			e <sub>1</sub>	e <sub>1</sub>							
22	39.000	1.200	100	140	558	220	68	70	4 ~ 8	132	16,326
			>140	180						140	17,720
			>180	200						142	18,440
25	52.000	1.050	100	140	635	240	68	80	4 ~ 8	168	26,596
			>140	180						177	28,292
			>180	200						191	31,404
28	84.000	950	100	160	712	260	80	80	5 ~ 9	240	48,80
			>160	200						245	50,64
			>200	240						260	54,80
31,5	110.000	850	125	180	800	290	80	90	5 ~ 9	322	81,80
			>180	220						328	84,68
			>220	260						353	91,84
36	150.000	750	140	220	905	320	90	100	5 ~ 10	440	144,44
			>220	260						474	153,28
			>260	290						496	164,76
40	195.000	680	150	240	1010	350	90	110	5 ~ 10	582	235,52
			>240	280						625	248,68
			>280	320						657	264,20
44	270.000	600	160	200	1118	380	100	120	6 ~ 11	763	395,4
			>200	250						775	402,4
			>250	300						842	424,8
49	345.000	550	>300	350	1248	420	100	130	6 ~ 11	882	449,2
			180	230						983	601,6
			>230	280						1.000	613,2
55	530.000	490	>280	330	1402	480	120	145	6 ~ 12	1.077	645,2
			>330	380						1.141	684,0
			200	260						1.469	1.126,4
63	750.000	430	>260	320	1604	540	120	165	6 ~ 12	1.494	1.149,6
			>320	380						1.609	1.213,2
			>380	440						1.692	1.289,6
71	975.000	380	>380	440	1805	600	140	185	8 ~ 16	2.068	2.030,8
			>440	500						2.109	2.079,2
			>500	540						2.261	2.175,2
79	1.300.000	340	>440	500	2006	660	140	200	8 ~ 16	2.328	2.254,8
			>500	560						3.063	3.821,2
			>560	600						3.111	3.900,8

\* Para el cálculo de la "J" dividir GD<sup>2</sup> / 4.

Los pesos de los cubos y el momento de inercia se refiere a los compromisos con orificio central.